

## 4 Channel 0/1-10V LED Dimming Driver

Model No.: RZ-VD-L4L-5A

0-10V or 1-10V signal input/PWM Constant voltage output/Logarithmic dimming/Push Dim



### Features

FC CE RoHS LVD

- 4 channel 0/1-10V LED dimming driver with push-dim function.
- 4 channel 0/1-10V input, 4 channel PWM constant voltage output.
- 0-100% dimming range via logarithmic characteristic can be very comfortable for human eyes.
- Compatible with active or passive 0-10V, 1-10V dimmer, can solve the fluorescent lamp dimming system compatible with LED lighting.

### Technical Parameters

Input and Output	
Input voltage	12-36VDC
Input current	20.5A
Output voltage	12-36VDC
Output current	4CH, 5A/CH
Output power	4 x (60-180)W
Output type	Constant voltage

Environment	
Operation temperature	Ta: -30°C ~ +55°C
Case temperature (Max.)	Tc: +85°C
IP rating	IP20

Warranty and Protection	
Warranty	5 years
Protection	Reverse Polarity

Safety and EMC	
Health	EN 62479:2010
Safety	EN 62368-1:2020+A1 1:2020
EMC	ETSI EN 301 489-1 V2.2.3
	ETSI EN 301 489-17 V3.2.4

Dimming data	
Input signal	0/1-10V + Push Dim
Dimming range	0-100%
Dimming curve	Logarithmic
PWM Frequency	500Hz

Weight	
Net weight	0.127kg
Gross weight	0.136kg

### Mechanical Structures and Installations

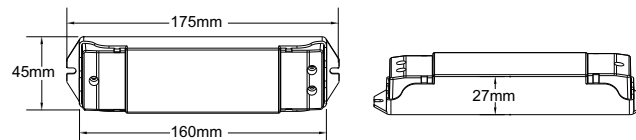
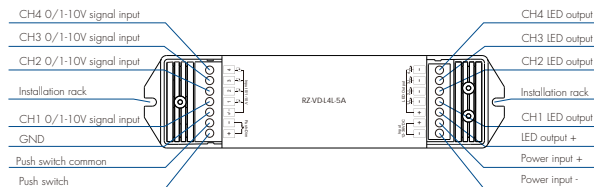

### Wiring Diagram

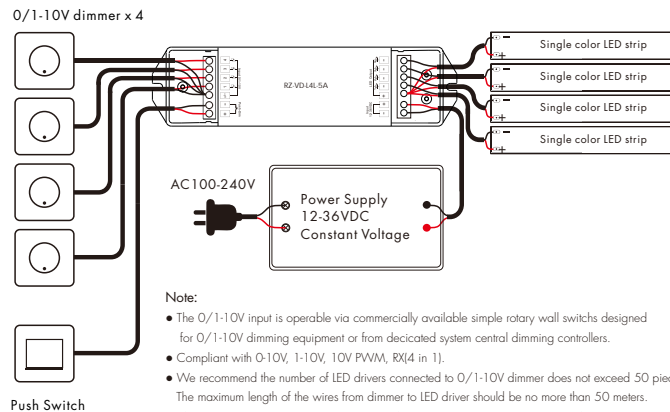

#### Note:

- The 0/1-10V input is operable via commercially available simple rotary wall switches designed for 0/1-10V dimming equipment or from dedicated system central dimming controllers.
- Compliant with 0-10V, 1-10V, 10V PWM, RX(4 in 1).
- We recommend the number of LED drivers connected to 0/1-10V dimmer does not exceed 50 pieces. The maximum length of the wires from dimmer to LED driver should be no more than 50 meters.
- If the LED driver be used with Push-Dim interface prior to using the 0/1-10V interface, the 0/1-10 V signal should change over 10% to return 0/1-10 V control.

## Push Dim Function

The provided Push-Dim interface allows for a simple dimming method using commercially available non-latching (momentary) wall switches.

- **Short press:**  
Turn on or off all 4 channel light.
- **Long press (1-6s):**  
Press and hold to step-less dimming, adjust 4 channel brightness at the same time.  
With every other long press, the light level goes to the opposite direction.
- **Dimming memory:**  
Light returns to the previous dimming level when switched off and on again, even at power failure.
- **Synchronization:**  
If more than one controller are connected to the same push switch, do a long press for more than 10s, then the system is synchronized and all lights in the group dim up to 100%.  
This means there is no need for any additional synchrony wire in larger installations.  
We recommend the number of controllers connected to a push switch does not exceed 50 pieces,  
The maximum length of the wires from push to controller should be no more than 50 meters.

## Dimming Curve

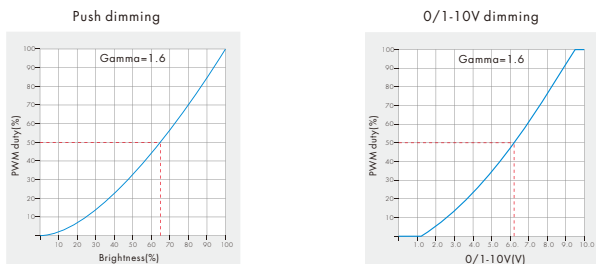

## Malfunctions Analysis & Troubleshooting

Malfunctions	Causes	Troubleshooting
No light	<ol style="list-style-type: none"> <li>1. No power.</li> <li>2. Wrong connection or insecure.</li> </ol>	<ol style="list-style-type: none"> <li>1. Check the power.</li> <li>2. Check the connection.</li> </ol>
Uneven intensity between front and rear; with voltage drop	<ol style="list-style-type: none"> <li>1. Output cable is too long.</li> <li>2. Wire diameter is too small.</li> <li>3. Overload beyond power supply capability.</li> <li>4. Overload beyond controller capability.</li> </ol>	<ol style="list-style-type: none"> <li>1. Reduce cable or loop supply.</li> <li>2. Change wider wire.</li> <li>3. Replace higher power supply.</li> <li>4. Add power repeater.</li> </ol>