

RZ-BR3-40

LED Emergency Driver 3-40W

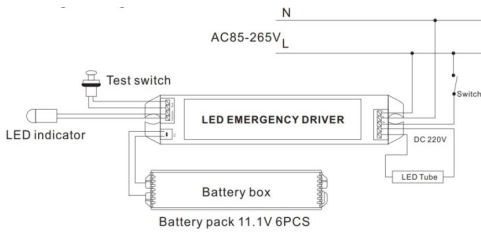

For LED light with external driver:

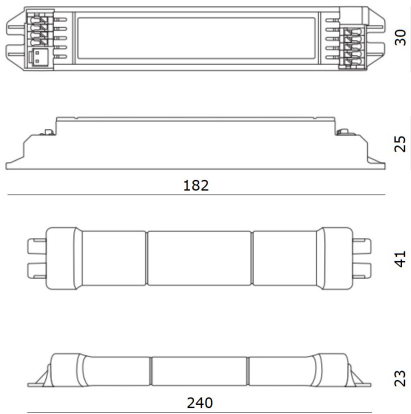
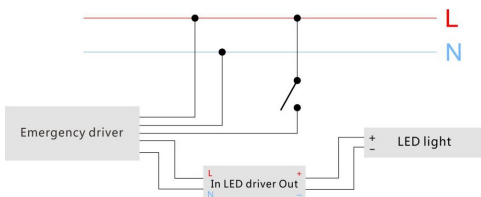

For LED light with internal driver:

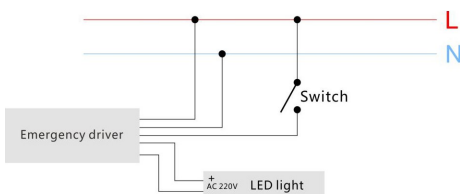

Description

Keep your lights up and running during a power failure by using the LED emergency driver with surge protection.

With this ballast and battery combination, your LEDs will shine at up to 1500 Lumens for at least 90 minutes in emergency mode.

It is designed for use in light fittings with various LED lamps.

With its compact size, it is versatile to be used in various environments with space constraints.

It comes with a highly efficient inverter to ensure long backup duration.

Safety Feature: High-voltage cut-off to prevent over-charge of battery;
Low-voltage cut-off to prevent over-discharge of battery.



Technical data

Description	LED emergency Driver
Lamp Compatibility	LED Lamps 3-40W
Input Voltage	85V-265VAC, 50-60Hz
Output Voltage	220VDC
Current	0.02A~0.1A
Emergency Wattage	Full 3-40W
Emergency Switch Time	≤0.5 s
Emergency Duration	180-60 mins
Recharge Period	≤24 hrs
Battery	Built-in 11.1V 4000mAh lithium ion
Battery cycle time	500 times recycling
Testing Facility	Test-switch for independent testing
Charging Monitor	LED
Charger	Fully automatic
Protection Degree	IP20
Operating Temperature	45°C ~ 60°C
Connector	Optional for DC/ VH / SM

Accessories

-

Notes

-